



Spare Parts Catalog

S 5-42

COMESA COMPONENTES MECANICOS S.A

Material number: 1307.050.410

Notes relating to the spare parts catalog

Setup of the spare parts catalog

- Cover sheet
- Technical Cover (only in SDM print)
- Overview of figures
- Figure
- Associated parts list
- Next figure
- Associated parts list
- ...

Figure and parts list



Overview of figures

Bildtafel Figure	Sachnummer Product number	Benennung (Description)	Technische Info Technical info	Description (Benennung)	Menge Quantity	Einheit Unit
068.08.17	1316.170.001	AUSLEGER	WL	SHIFT TURRET	1	Stk
068.08.06	1316.170.031	DECKEL	WL*H-H *VM	COVER	1	Stk
068.08.14	1316.170.808	DECKEL	WL*AUSL+GEH*H-H*HF160N	COVER	1	Stk
08	1316.170.441	ANSCHLUSSTEILE	WL*NG-VORB*RG-SCHL*168N *BAJONETT	CONNECTING PARTS	1	Stk

The "gap" indicates that there is no separate graphics panel (poster) for this assembly
The parts of this assembly are shown with the same mid-section number on the figure

1 Positions and subpositions

Pos.	Sachnummer Product number	Benennung (Description)	Technische Info Technical info	Description (Benennung)	Menge Quantity	Einheit Unit
0370	1315.201.054	RUECKLAUFBOLZEN	KPL.16S151*SG*L= 79	REV.IDLER SHAFT	1	Stk
/0120	0631.329.293	SPANNSTIFT		SLOT. PIN	1	Stk

Positions marked with "/" are the individual items of a completion
For example: Position 0370 contains a centering pin with the position /0120

2 Combinations with standardized parts

Pos.	Sachnummer Product number	Benennung (Description)	Technische Info Technical info	Description (Benennung)	Menge Quantity	Einheit Unit
0630		VERSCHL.SCHR.		SCREW PLUG	1	Stk
	0636.302.067	VERSCHL.SCHR.		SCREW PLUG	1	Stk
	0634.801.249	DICHTRING	A 26 X 31	SEALING RING	1	Stk

The parts list shows the components included in the combination of standardized parts

3 Depiction of position/item number on the figure and in the parts list

01.620 - on the figure 01 relates to the assembly in which the position is included. Due to program-related reasons, it is shown on the figure.

0620 - in the parts list

Pos.	Sachnummer Product number	Benennung (Description)	Technische Info Technical info	Description (Benennung)	Menge Quantity	Einheit Unit
0620	0732.040.736	DRUCKFEDER		COMPRESSION SPRING	1	Stk

4 *-Positions

Positions marked with an * are optional i.e. inclusion in the parts list is not mandatory.
The following note is shown on the figure

je nach Stücklistenausführung
depending on spec. number
*
suivant la nomenclature
secondo la distinta base

5 Parts, dotted display

Parts with dotted display on the figure are only used for orientation of other parts



Pos.	Information	Amendment number
001	Use case -----	
002	Customer KURGAN BUS	
003	City KURGAN	
004	DUNS 53-494-8526	
005	Vehicle / Apparatus -----	
006	Sales Name KAVZ 4235	
007	Manufacturer KURGAN BUS	
008	Engineering Name	
009	Product Use BUS	
010	Vehicle/Hardware Type MIDIBUS	
011	SOP	
012	Engine	
013	Sales Designation ISBE4 185B	
014	Manufacturer Cummins Engine Co.	
015	Drivetrain type DIESEL	
016	Eng.Displ. cm3	
017	Cylinder	
018	Nom. power 136 kW	
019	RPM at nom. power 2500 1/min	
020	Nom. torque 550 Nm	
021	RPM at nom. torque 1500 1/min	
022	Classification use case -----	
023	APPROVAL NOTE 1 ERSTEINBAU*UEBERPRUEFUNG ERFORDERLICH	
027	DESIGNATION, CLUTCH MF362	
028	MANUFACTURER, CLUTCH ZF-SACHS	
033	DYNAMIC TYRE RADIUS 447 mm	
034	REAR AXLE RATIO 5.29	
035	MAXIMUM SPEED 100 km/h	
038	PERMISS.GROSS VEHICLE WEIGHT 11 t	
040	ADDITIONAL DESIGNATION, ENGINE NEIG=4 GRAD 30MIN.	
042	Product description -----	
043	INSTALLATION POS TRANSMISSION VERTICAL	



Pos.	Information	Amendment number
044	TRANSMISSION ATTACHMENT FLANGE-MOUNTED	
045	RATIO, BOTTOM GEAR 4.65	
046	RATIO, TOP GEAR .77	
047	SET OF RATIOS SG	
048	RATIO, 1ST GEAR 4.65	
049	RATIO, 2ND GEAR 2.6	
050	RATIO, 3RD GEAR 1.53	
051	RATIO, 4TH GEAR 1	
052	RATIO, 5TH GEAR .77	
053	RATIO, 1ST GEAR REVERSE 4.35	
054	DESIGN, SHIFT SYSTEM TURNING SHAFT	
055	POSITION, GEAR SHIFT SYSTEM HORIZONTAL RIGHT	
057	DESIGN, SEPARATING CLUTCH FULL-SYNCHRONIZED	
058	REFERENCE LENGTH INPUT SHAFT -104 mm	
059	STANDARD TYPE INPUT SHAFT SAE	
061	NORMEN IDENTNUMMER ANTR.WELLE 10C	
062	NOMINAL DIAMETER INPUT SHAFT 1,500	
074	DESIGN,CONN., CLUTCH HOUSING SAE 3	
079	DIAMETER, RELEASE FLANGE 57 mm	
080	TYPE FIT RELEASE BEARING FLA. E8	
081	DESIGN BEARING OUTPUT STANDARD SUSPENSION	
082	OUTER DIA. OUTPUT FLANGE RA 155 mm	
084	NO.OF BORES OUTPUT FLANGE HA1 4	
085	BORE DIA. OUTPUT FLANGE RA 13 mm	
088	REF. LENGTH OUTPUT FLANGE RA 619 mm	
092	DIMENSION SHIFT TURRET DIST. 208 mm	
093	MEAS. LOC. SHIFT TURRET DIST. SHIFT LEVER-LOCATION	
115	SELECTION PATTERN VARIANT INSTALLATION DRAWING	
118	SWITCH, REVERSE GEAR y	
119	DESIGN, RG (REV.GEAR) SWITCH CLOSING	
120	NOTE ON SWITCH, REVERSE GEAR GEAR SHIFT RAIL	
121	PROT. CAP SWITCH, REVERSE GEAR y	



Pos.	Information	Amendment number
122	DESIGN, CONNECTION, RG SWITCH DIN BAYONET	
123	LENGTH CONNECTION RG-SWITCH mm	
124	SWITCH, NEUTRAL GEAR y	
125	DESIGN,NG(NEUTRAL GEAR)SWITCH OPENING SWITCH	
126	PROT.CAP SWITCH, NEUTRAL GEAR y	
127	DESIGN, CONNECTION, NG SWITCH DIN BAYONET	
128	LENGTH CONNECTION NG-SWITCH mm	
131	REF.LENGTH,RELEASE BEAR.FLAN -12 mm	
133	TYPE OF RELEASE MECHANISM WITH	
136	VERSION OF CLUTCH HOUSING INTEGRATED	
137	ASSEMBLY POS. CLUTCH CYLINDER 9	
138	VERSION OF CLUTCH CYLINDER SERVO	
139	AUSF BETAETIGUNG KUPPLUNG D=75.0	
140	EINBAUMASS KUPPLUNGSGEHAEUSE 145 mm	
146	DESIGN RELEASE BEARING WITHOUT GROOVE	
147	WRENCH SIZE, RELEASE FORK 75 mm	
151	NO. PULSES PULSE SENSOR SFAH68 6 IMP/U	
153	VERSION PULSE SENSOR SFA H68 WITH	
155	PROT. CAP PULSE SENSOR SFA H68 y	
158	CABLE LENGTH PULSE SENSOR SFA H68 mm	
159	DESIG,CONN,PULSE SENS. SFA H68 DIN BAYONET	
196	OIL CAPACITY, GEARBOX 3.2 dm3	
199	OIL GRADE PERMISSIBLE ACC. TO TE-ML02	
201	COLOR JET BLACK	
202	COLOUR CLASSIFICATION ACC. TO RAL 9005	
204	PAINTING, ZF STANDARD 915 W	
205	CODING OUTER CONSERVATION KA1	
206	CODING INNER CONSERVATION KI2	
207	SCOPE OUTER CONSERVATION T	
208	CONSERVATION SPECIFICATION ZFN 916	
209	Documents -----	
210	SCHALTGETRIEBE Drawing 1307.050.701	



Pos.	Information	Amendment number
211	DREHW.SCHALTUNG Drawing 1307.607.001	
212	5-SPEED GEARBOX Assembly 1307.650.012	
213	5-SPEED GEARBOX Drawing 1307.650.012	
214	1307.050.305 Drawing 1307.050.305	

Assembly group overview

Material number: 1307.050.410

S 5-42 / COMESA COMPONENTES MECANICOS S.A

Page 1 from 1



Graphics	Pos.	Material number	Name	Quantity	Amend. no.	Techn. Info.
067.01.12-1	110	1307.101.138	GEARBOX HOUSING	1		
067.02.04-1	130	1307.102.080	INPUT SHAFT	1		
067.03.01-1	160	1307.103.011	LAYSHAFT	1		
067.04.04-1	200	1307.104.200	MAIN SHAFT	1		
067.04.82-1	210	1307.104.813	MAIN SHAFT	1		
067.05.01-1	220	1307.105.007	RETURN	1		
067.06.05-1	230	1307.106.046	GEAR SHIFT SYSTEM	1		
067.06.40-1	238	1307.106.433	CONNECTING PARTS	1		
067.07.02-1	20	1307.107.018	GEAR SHIFT SHAFT	1		
067.07.02-1	280	1307.107.800	GEAR SHIFT HOUSING	1		
067.07.02-1	900	1307.107.020	GEAR SHIFT HOUSING	1		
067.07.02-1	910	1307.107.017	GEAR SHIFT SHAFT	1		
067.93.31-1	140	1307.168.012	CLUTCH RELEASE DEVICE	1		
067.93.69-1	142	1307.168.405	CLUTCH RELEASE DEVICE	1		

Plant

Page 1 from 1

Material number: 1307.050.410

Plant: 067.01.12-1

Material-assembly-group-no: 1307.101.138

S 5-42 / COMESA COMPONENTES MECANICOS S.A

GEARBOX HOUSING



Bildtafel:
Figure: 067.01.12
Figure:
Figura:

je nach Stücklistenausführung
depending on spec. number
* suivant la nomenclature
secondo la distinta base

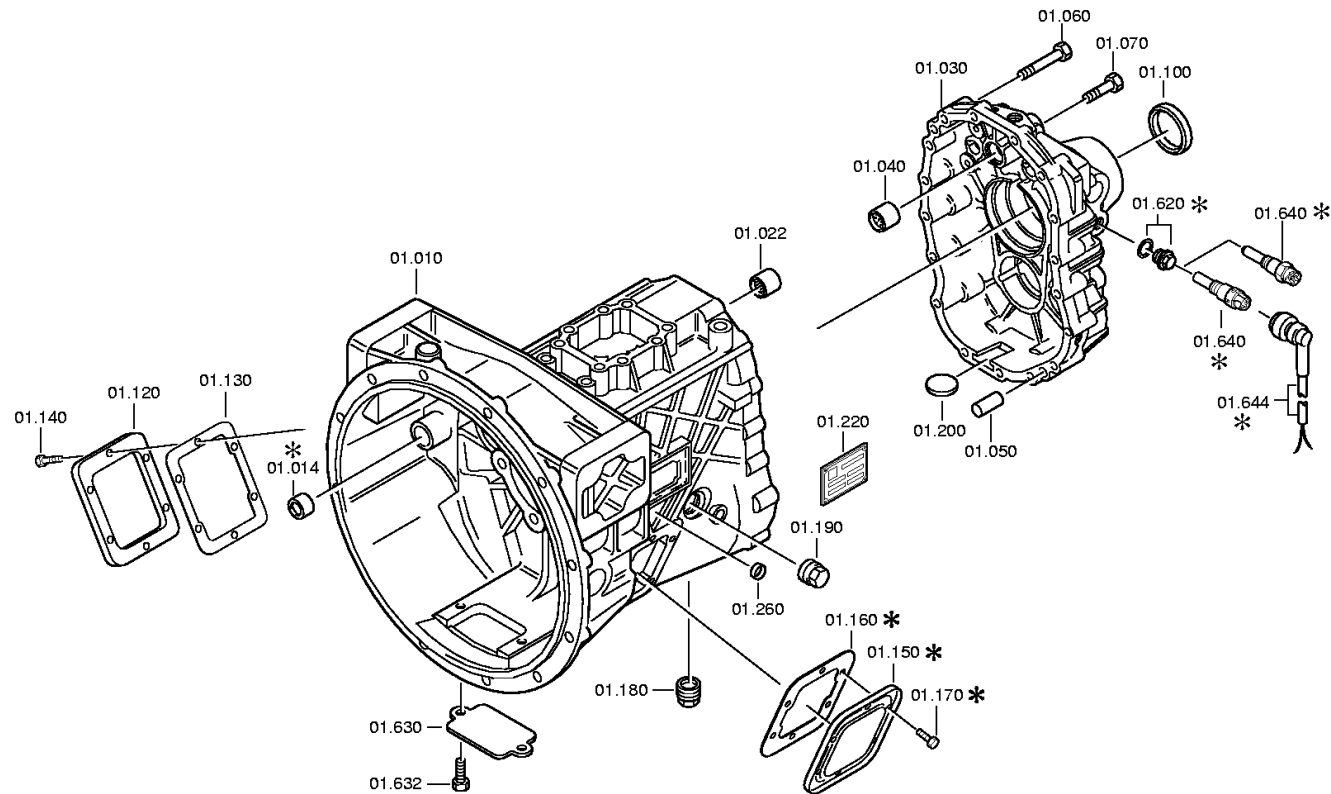

Parts list

Page 1 from 1

Material number: 1307.050.410

S 5-42 / COMESA COMPONENTES MECANICOS S.A

Plant: 067.01.12-1

Material-assembly-group-no: 1307.101.138



Pos.	Material number	Customer material	Name	Quantity	ME	Amend. no.	Techn. Info.	Weight	Rep kit	Alternative material
10	1307.201.055		HOUSING	1			KPL.	0,000		
22	0750.115.238		BALL SLEEVE	1			18,0X24,0X24,0	0,000		
30	1307.301.253		OUTPUT HOUSING	1				0,000		
40	0750.115.238		BALL SLEEVE	1			18,0X24,0X24,0	0,000		
50	0631.306.232		CYLINDRICAL PIN	2			12X24	0,000		
60	0636.011.757		HEXAGON BOLT	15		Z00007051312	M8X55	0,000		
70	0636.100.628		HEXAGON BOLT	2			M8X35	0,000		
100	0734.319.652		SHAFT SEAL	1		C01005077B10	50X65X8	0,000		
120	1324.301.165		COVER	1		Z00009633112		0,000		
130	1290.301.140		GASKET	1			ENTHALT.IN 1290 301 071(1)	0,000		
140	0636.100.404		HEXAGON BOLT	6		Z00009176710	M10X22	0,000		
150	1324.301.165		COVER	1		Z00009633112		0,000		
160	1290.301.140		GASKET	1			ENTHALT.IN 1290 301 071(1)	0,000		
170	0636.100.404		HEXAGON BOLT	6		Z00009176710	M10X22	0,000		
180	---		SCREW PLUG	1			50N.M*O.DICHTRING M24X1,5	0,000		
---	0736.303.005		SCREW PLUG	1				0,000		
190	---		SCREW PLUG	1			50N.M*O.DICHTRING M24X1,5	0,000		
---	0736.303.005		SCREW PLUG	1				0,000		
200	1048.301.010		SOLENOID	1				0,000		
220	0730.365.260		TYPE PLATE	1				0,000		
260	0630.100.029		SEALING CAP	1		Z00007166013		0,000		
630	1307.301.224		COVER	1		C01000653A10		0,000		
632	0636.100.561		HEXAGON BOLT	2		Z00007073111	M5X10	0,000		
640	---		PULSE SENSOR	1			45N.M*O.DICHTRING* BAJONETT*L=25,0	0,000		
---	0501.210.856		PULSE SENSOR	1				0,000		

Plant

Page 1 from 1

Material number: 1307.050.410

Plant: 067.02.04-1

Material-assembly-group-no: 1307.102.080

S 5-42 / COMESA COMPONENTES MECANICOS S.A

INPUT SHAFT

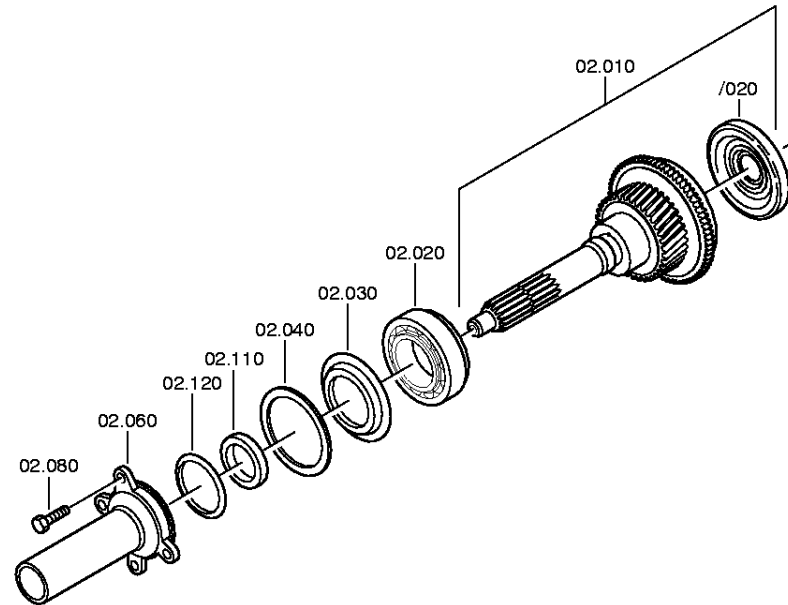

Parts list

Page 1 from 2

Material number: 1307.050.410

Plant: 067.02.04-1

Material-assembly-group-no: 1307.102.080

S 5-42 / COMESA COMPONENTES MECANICOS S.A



Pos.	Material number	Customer material	Name	Quantity	ME	Amend. no.	Techn. Info.	Weight	Rep kit	Alternative material
10	1307.202.169		INPUT SHAFT	1		C01008053D10	KPL.L=238*SAE 1 1/2*4,65_	0,000		
/20	0750.190.014		OIL DAM	1			46X92X5,5	0,000		
20	---		TAROLLBEARING	1				0,000		
---	1307.202.116		TAROLLBEARING	1			KPL.	0,000		
---	1307.202.018		TAROLLBEARING	1			KPL.50,8X92,0X25,4	0,000		
30	0750.112.061		RING	1			56,0X91,9X3,0	0,000		
40	---		WASHER	1			S= 1,20- 2,00(ABSTUFUNG:0,05MM)	0,000		
---	0730.105.768		WASHER	1			A=2,00 IN 0730 105 762(1)	0,000		
---	0730.106.204		WASHER	1			A=1,95 IN 0730 105 762(1)	0,000		
---	0730.105.767		WASHER	1			A=1,90 IN 0730 105 762(1)	0,000		
---	0730.106.203		WASHER	1			A=1,85 IN 0730 105 762(1)	0,000		
---	0730.105.766		WASHER	1			A=1,80 IN 0730 105 762(1)	0,000		
---	0730.106.202		WASHER	1			A=1,75 IN 0730 105 762(1)	0,000		
---	0730.105.765		WASHER	1			A=1,70 IN 0730 105 762(1)	0,000		
---	0730.106.201		WASHER	1			A=1,65 IN 0730 105 762(1)	0,000		
---	0730.105.764		WASHER	1			A=1,60 IN 0730 105 762(1)	0,000		
---	0730.106.200		WASHER	1			A=1,55 IN 0730 105 762(1)	0,000		
---	0730.105.763		WASHER	1			A=1,50 IN 0730 105 762(1)	0,000		

Parts list

Page 2 from 2

Material number: 1307.050.410

Plant: 067.02.04-1

Material-assembly-group-no: 1307.102.080

S 5-42 / COMESA COMPONENTES MECANICOS S.A



Pos.	Material number	Customer material	Name	Quantity	ME	Amend. no.	Techn. Info.	Weight	Rep kit	Alternative material
---	0730.106.689		WASHER	1			A=1,45 IN 0730 105 762(1)	0,000		
---	0730.106.688		WASHER	1			A=1,40 IN 0730 105 762(1)	0,000		
---	0730.106.687		WASHER	1			A=1,35 IN 0730 105 762(1)	0,000		
---	0730.106.686		WASHER	1			A=1,30 IN 0730 105 762(1)	0,000		
---	0730.106.685		WASHER	1			A=1,25 IN 0730 105 762(1)	0,000		
---	0730.106.684		WASHER	1			A=1,20 IN 0730 105 762(1)	0,000		
60	1307.302.137		BEARING FLANGE	1		C01008053D10	ENTHALT.IN 1307 302 146(1)	0,000		
80	0636.100.797		HEXAGON BOLT	4		Z00007891312	M8X30	0,000		
110	0734.310.397		SHAFT SEAL	1		C01008053D10	48X65X8/10 FA.CFW	0,000		
120	0634.303.053		O-RING	1			85X4	0,000		

Plant

Page 1 from 1

Material number: 1307.050.410

Plant: 067.03.01-1

Material-assembly-group-no: 1307.103.011

S 5-42 / COMESA COMPONENTES MECANICOS S.A
LAYSHAFT

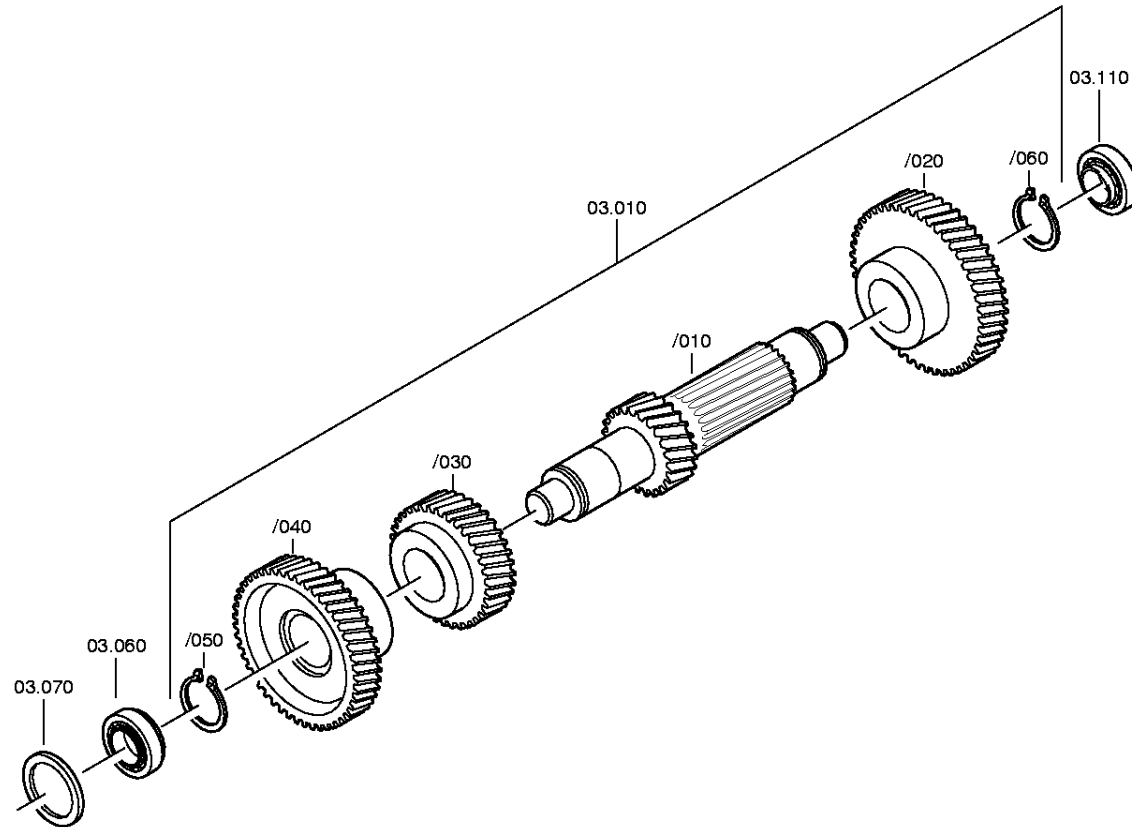

Parts list

Page 1 from 2

Material number: 1307.050.410

Plant: 067.03.01-1

Material-assembly-group-no: 1307.103.011

S 5-42 / COMESA COMPONENTES MECANICOS S.A



Pos.	Material number	Customer material	Name	Quantity	ME	Amend. no.	Techn. Info.	Weight	Rep kit	Alternative material
10	1307.203.046		LAYSHAFT	1		C01004601A10	KPL. IN 1307 203 045(1)	0,000		
/10	1307.303.107		LAYSHAFT	1			ENTHALT.IN 1307 303 103(0)	0,000		
/20	1317.303.016		HELICAL GEAR	1			5G/Z48 IN 1317 303 017(1)	0,000		
/30	1307.303.116		HELICAL GEAR	1			3G/Z30 IN 1317 303 014(1)	0,000		
/40	1307.303.123		HELICAL GEAR	1			Z43 IN 1307 303 121(1)	0,000		
/50	0630.501.033		RETAINING RING	1			45X1,75	5		
/60	0630.501.031		RETAINING RING	1			40X1,75	4		
60	---		TAROLLBEARING	1				0,420		
---	1307.203.019		TAROLLBEARING	1				0,420		
---	1307.203.010		TAROLLBEARING	1				0,000		
---	1307.203.009		TAROLLBEARING	1				0,000		
70	---		WASHER	1			S= 1,40- 2,00(ABSTUFUNG:0,05MM)	0,000		
---	0730.004.837		WASHER	1			A=2,00 IN 0730 004 828(2)	0,000		
---	0730.004.836		WASHER	1			A=1,95 IN 0730 004 828(2)	0,000		
---	0730.004.835		WASHER	1			A=1,90 IN 0730 004 828(2)	0,000		
---	0730.004.834		WASHER	1			A=1,85 IN 0730 004 828(2)	0,000		
---	0730.004.833		WASHER	1			A=1,80 IN 0730 004 828(2)	0,000		
---	0730.004.832		WASHER	1			A=1,75 IN 0730 004 828(2)	0,000		
---	0730.004.831		WASHER	1			A=1,70 IN 0730 004 828(2)	0,000		
---	0730.004.969		WASHER	1			A=1,65 IN 0730 004 828(2)	0,000		

Parts list

Page 2 from 2

Material number: 1307.050.410

Plant: 067.03.01-1

Material-assembly-group-no: 1307.103.011

S 5-42 / COMESA COMPONENTES MECANICOS S.A



Pos.	Material number	Customer material	Name	Quantity	ME	Amend. no.	Techn. Info.	Weight	Rep kit	Alternative material
---	0730.004.830		WASHER	1			A=1,60 IN 0730 004 828(2)	0,000		
---	0730.004.968		WASHER	1			A=1,55 IN 0730 004 828(2)	0,000		
---	0730.004.829		WASHER	1			A=1,50 IN 0730 004 828(2)	0,000		
---	0730.006.221		WASHER	1			A=1,45 IN 0730 004 828(2)	0,000		
---	0730.006.220		WASHER	1			A=1,40 IN 0730 004 828(2)	0,000		
110	---		TAROLLBEARING	1				0,420		
---	1307.203.019		TAROLLBEARING	1				0,420		
---	1307.203.010		TAROLLBEARING	1				0,000		
---	1307.203.009		TAROLLBEARING	1				0,000		

Plant

Page 1 from 2

Material number: 1307.050.410
Plant: 067.04.04-1
MAIN SHAFT

S 5-42 / COMESA COMPONENTES MECANICOS S.A
MAIN SHAFT

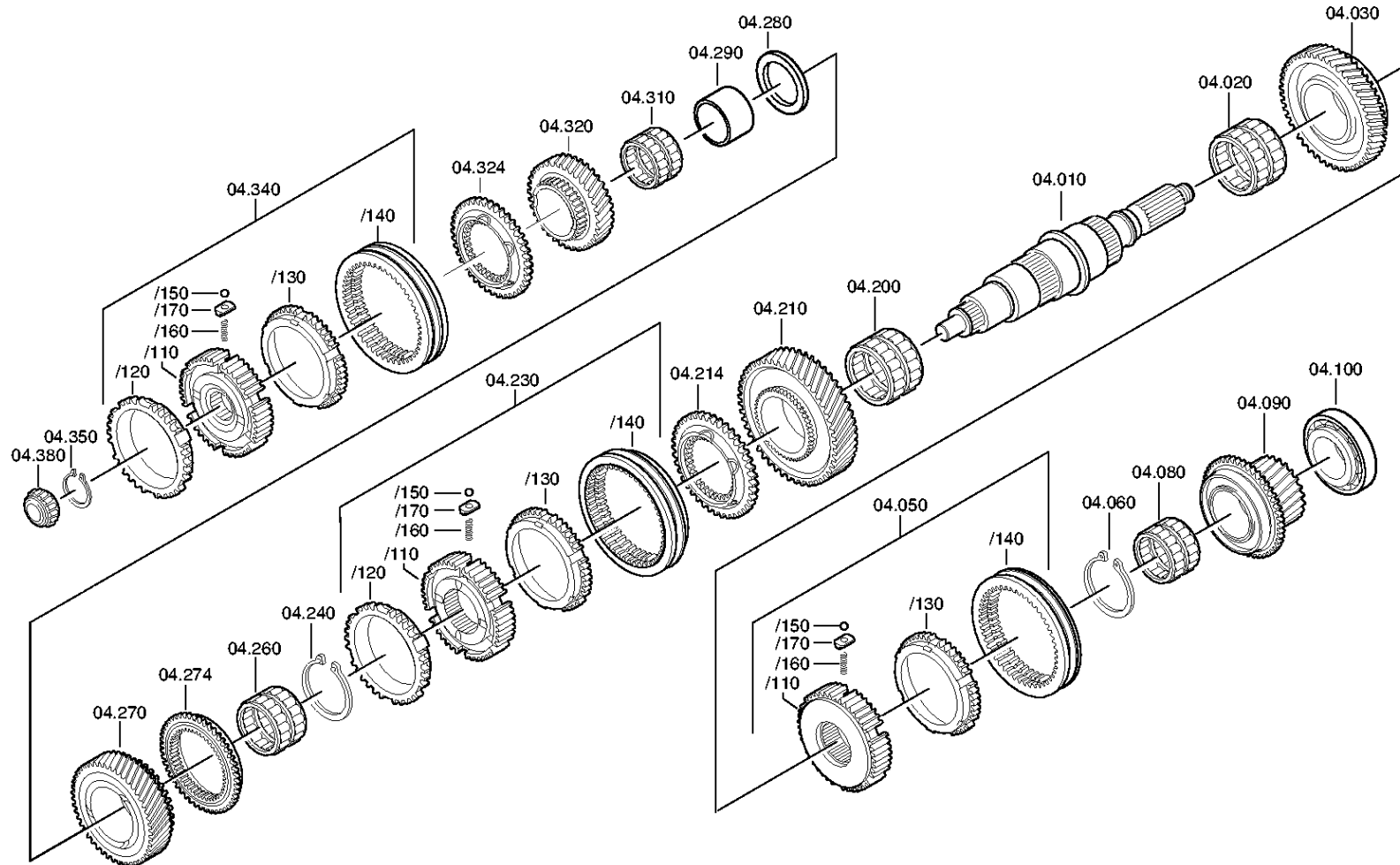

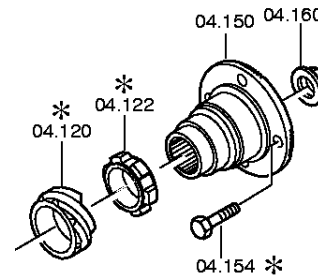

Parts list

Page 1 from 4

Material number: 1307.050.410

Plant: 067.04.04-1

Material-assembly-group-no: 1307.104.200

S 5-42 / COMESA COMPONENTES MECANICOS S.A



Pos.	Material number	Customer material	Name	Quantity	ME	Amend. no.	Techn. Info.	Weight	Rep kit	Alternative material
10	1307.304.623		MAIN SHAFT	1			ENTHALT.IN 1307 304 548(0)	0,000		
20	0735.320.873		NEEDLE CAGE	1				0,120		
30	1307.304.650		HELICAL GEAR	1			RG IN 1307 304 648(0)	0,000		
50	1307.204.293		SYNCHRONIZER	1			KPL.RG+5G*SG* / SIN*RG-KL	0,000		
/110	1307.204.230		SYNCHROBODY	1			KPL.	0,000		
/130	1307.304.182		SYNCHRO RING	1			ENTHALT.IN 1307 304 264(0)	0,000		
/140	1307.304.671		SLIDING SLEEVE	1		Z00007384710	ZF-B100 I	0,000		
/150	0635.460.010		BALL	3			6	1		
/160	0732.041.571		COMPRSPRING	3				0,000		
/170	1307.304.156		PRESSURE PIECE	3			ENTHALT.IN 1307 304 155(1)	0,000		
60	---		RETAINING RING	1			S= 1,80- 2,40(ABSTUFUNG:0,05MM)	0,000		
---	0730.501.407		RETAINING RING	1		C01007890210	A=2,40 IN 0730 501 404(2)	0,000		
---	0730.501.406		RETAINING RING	1		C01007890210	A=2,35 IN 0730 501 404(2)	0,000		
---	0730.501.405		RETAINING RING	1		C01007890210	A=2,30 IN 0730 501 404(2)	0,000		
---	0730.501.506		RETAINING RING	1		C01007890210	A=2,25 IN 0730 501 404(2)	0,000		
---	0730.501.314		RETAINING RING	1				0,010		
---	0730.501.544		RETAINING RING	1			A=2,15 IN 0730 501 263(2)	0,000		
---	0730.501.299		RETAINING RING	1				0,010		
---	0730.501.543		RETAINING RING	1			A=2,05 IN 0730 501 263(2)	0,000		
---	0730.501.542		RETAINING RING	1			A=2,00 IN 0730 501 263(2)	0,000		

Parts list

Page 2 from 4

Material number: 1307.050.410

Plant: 067.04.04-1

Material-assembly-group-no: 1307.104.200

S 5-42 / COMESA COMPONENTES MECANICOS S.A



Pos.	Material number	Customer material	Name	Quantity	ME	Amend. no.	Techn. Info.	Weight	Rep kit	Alternative material
---	0730.501.541		RETAINING RING	1			A=1,95 IN 0730 501 263(2)	0,000		
---	0730.501.265		RETAINING RING	1				0,010		
---	0730.501.540		RETAINING RING	1			A=1,85 IN 0730 501 263(2)	0,000		
---	0730.501.264		RETAINING RING	1				0,010		
80	0735.321.010		NEEDLE CAGE	1			43,0X48,0X39,5 FA.INA	0,000		
90	1307.204.325		HELICAL GEAR	1			KPL.5G IN 1317 204 020(1)	0,000		
100	---		TAROLLBEARING	1				0,000		
---	1307.204.275		TAROLLBEARING	1			KPL.42,0X92,0X25,4	0,000		
---	1307.204.056		TAROLLBEARING	1			KPL.42,0X92,0X25,4	0,000		
122	1307.304.592		PULSE DISC	1				0,000		
150	1307.304.602		OUTPUT FLANGE	1			KV155	0,000		
160	---		LOCKING NUT	1			M24X1,5	0,000		
---	1317.304.117		LOCKING NUT	1			M24X1,5 IN 1317 304 096(2)	0,000		
200	0735.320.873		NEEDLE CAGE	1				0,120		
210	1307.304.653		HELICAL GEAR	1			1G IN 1307 304 651(0)	0,000		
214	1307.304.628		CLUTCH BODY	1			ENTHALT.IN 1307 304 627(1)	0,000		
230	1307.204.266		SYNCHRONIZER	1			KPL.1+2G*SG* ST/ST	0,000		
/110	1307.304.608		SYNCHROBODY	1			1+2G	0,000		
/120	1307.304.644		SYNCHROBODY	1		C01001161B10		0,000		
/130	1307.304.644		SYNCHROBODY	1		C01001161B10		0,000		
/140	1307.304.668		SLIDING SLEEVE	1		Z00007384712	ZF-B115 I	0,000		
/150	0635.460.010		BALL	3			6	1		
/160	0732.041.571		COMPRSPRING	3				0,000		
/170	1307.304.156		PRESSURE PIECE	3			ENTHALT.IN 1307 304 155(1)	0,000		

Parts list

Page 3 from 4

Material number: 1307.050.410

Plant: 067.04.04-1

Material-assembly-group-no: 1307.104.200

S 5-42 / COMESA COMPONENTES MECANICOS S.A



Pos.	Material number	Customer material	Name	Quantity	ME	Amend. no.	Techn. Info.	Weight	Rep kit	Alternative material
240	---		RETAINING RING	1			S= 1,80- 2,40(ABSTUFUNG:0,05MM)	0,000		
---	0730.501.407		RETAINING RING	1		C01007890210	A=2,40 IN 0730 501 404(2)	0,000		
---	0730.501.406		RETAINING RING	1		C01007890210	A=2,35 IN 0730 501 404(2)	0,000		
---	0730.501.405		RETAINING RING	1		C01007890210	A=2,30 IN 0730 501 404(2)	0,000		
---	0730.501.506		RETAINING RING	1		C01007890210	A=2,25 IN 0730 501 404(2)	0,000		
---	0730.501.314		RETAINING RING	1				0,010		
---	0730.501.544		RETAINING RING	1			A=2,15 IN 0730 501 263(2)	0,000		
---	0730.501.299		RETAINING RING	1				0,010		
---	0730.501.543		RETAINING RING	1			A=2,05 IN 0730 501 263(2)	0,000		
---	0730.501.542		RETAINING RING	1			A=2,00 IN 0730 501 263(2)	0,000		
---	0730.501.541		RETAINING RING	1			A=1,95 IN 0730 501 263(2)	0,000		
---	0730.501.265		RETAINING RING	1				0,010		
---	0730.501.540		RETAINING RING	1			A=1,85 IN 0730 501 263(2)	0,000		
---	0730.501.264		RETAINING RING	1				0,010		
260	0735.320.871		NEEDLE CAGE	1				0,120		
270	1307.304.633		HELICAL GEAR	1			ENTHALT.IN 1307 304 631(1)	0,000		
274	1307.304.628		CLUTCH BODY	1			ENTHALT.IN 1307 304 627(1)	0,000		
280	0730.106.561		WASHER	1			A=5,00 IN 0730 106 560(1)	0,000		

Parts list

Page 4 from 4

Material number: 1307.050.410

Plant: 067.04.04-1

Material-assembly-group-no: 1307.104.200

S 5-42 / COMESA COMPONENTES MECANICOS S.A



Pos.	Material number	Customer material	Name	Quantity	ME	Amend. no.	Techn. Info.	Weight	Rep kit	Alternative material
290	0730.162.428		BUSH	1			A=42,30 IN 0730 161 688(2)	0,000		
310	0735.320.871		NEEDLE CAGE	1				0,120		
320	1307.304.640		HELICAL GEAR	1			ENTHALT.IN 1307 304 636(1)	0,000		
324	1307.304.626		CLUTCH BODY	1			ENTHALT.IN 1307 304 625(1)	0,000		
340	1307.204.317		SYNCHRONIZER	1			KPL.3+4G*SG*ST/SIN	0,000		
/110	1307.304.607		SYNCHROBODY	1			3+4G	0,000		
/120	1307.304.182		SYNCHRO RING	1			ENTHALT.IN 1307 304 264(0)	0,000		
/130	1307.304.643		SYNCHRO RING	1		C01001160B10	ENTHALT.IN 1307 304 645(1)	0,000		
/140	1307.304.669		SLIDING SLEEVE	1		Z00007384713	ZF-B100 I	0,000		
/150	0635.460.010		BALL	3			6	1		
/160	0732.041.571		COMPRSPRING	3				0,000		
/170	1307.304.156		PRESSURE PIECE	3			ENTHALT.IN 1307 304 155(1)	0,000		
350	---		RETAINING RING	1			S= 1,80- 2,20(ABSTUFUNG:0,10MM)	0,000		
---	0730.501.301		RETAINING RING	1			A=2,20 IN 0730 501 259(2)	0,000		
---	0730.501.300		RETAINING RING	1			A=2,10 IN 0730 501 259(2)	0,000		
---	0730.501.262		RETAINING RING	1			A=2,00 IN 0730 501 259(2)	0,000		
---	0730.501.261		RETAINING RING	1			A=1,90 IN 0730 501 259(2)	0,000		
---	0730.501.260		RETAINING RING	1			A=1,80 IN 0730 501 259(2)	0,000		
380	0750.117.251		TAROLLBEARING	1			24,0X28,5	0,000		

Plant

Page 1 from 1

Material number: 1307.050.410

Plant: 067.05.01-1

Material-assembly-group-no: 1307.105.007

S 5-42 / COMESA COMPONENTES MECANICOS S.A

RETURN

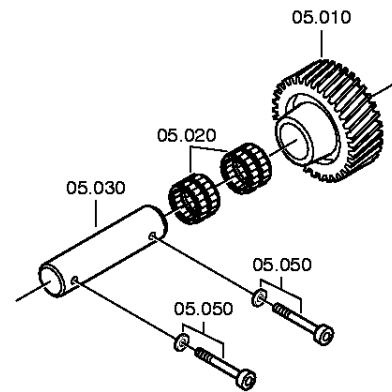

Parts list

Page 1 from 1

Material number: 1307.050.410

Plant: 067.05.01-1

Material-assembly-group-no: 1307.105.007

S 5-42 / COMESA COMPONENTES MECANICOS S.A



Pos.	Material number	Customer material	Name	Quantity	ME	Amend. no.	Techn. Info.	Weight	Rep kit	Alternative material
10	1307.305.026		IDLER GEAR	1			RG IN 1307 305 024(1)	0,000		
20	0750.115.233		NEEDLE CAGE	2			30,0X38,0X30,0	0,000		
30	1307.305.003		PIN	1			ENTHALT.IN 1307 305 021(2)	0,000		
50	---		CAP SCREW	2			M8X50	0,000		
---	0636.115.295		CAP SCREW	2		Z00007399816	M8X50	0,000		
---	0630.050.016		USIT RING	2			8,7X13X1	0,000		

Plant

Page 1 from 2

Material number: 1307.050.410

Plant: 067.06.05-1

GEAR SHIFT SYSTEM

S 5-42 / COMESA COMPONENTES MECANICOS S.A

GEAR SHIFT SYSTEM

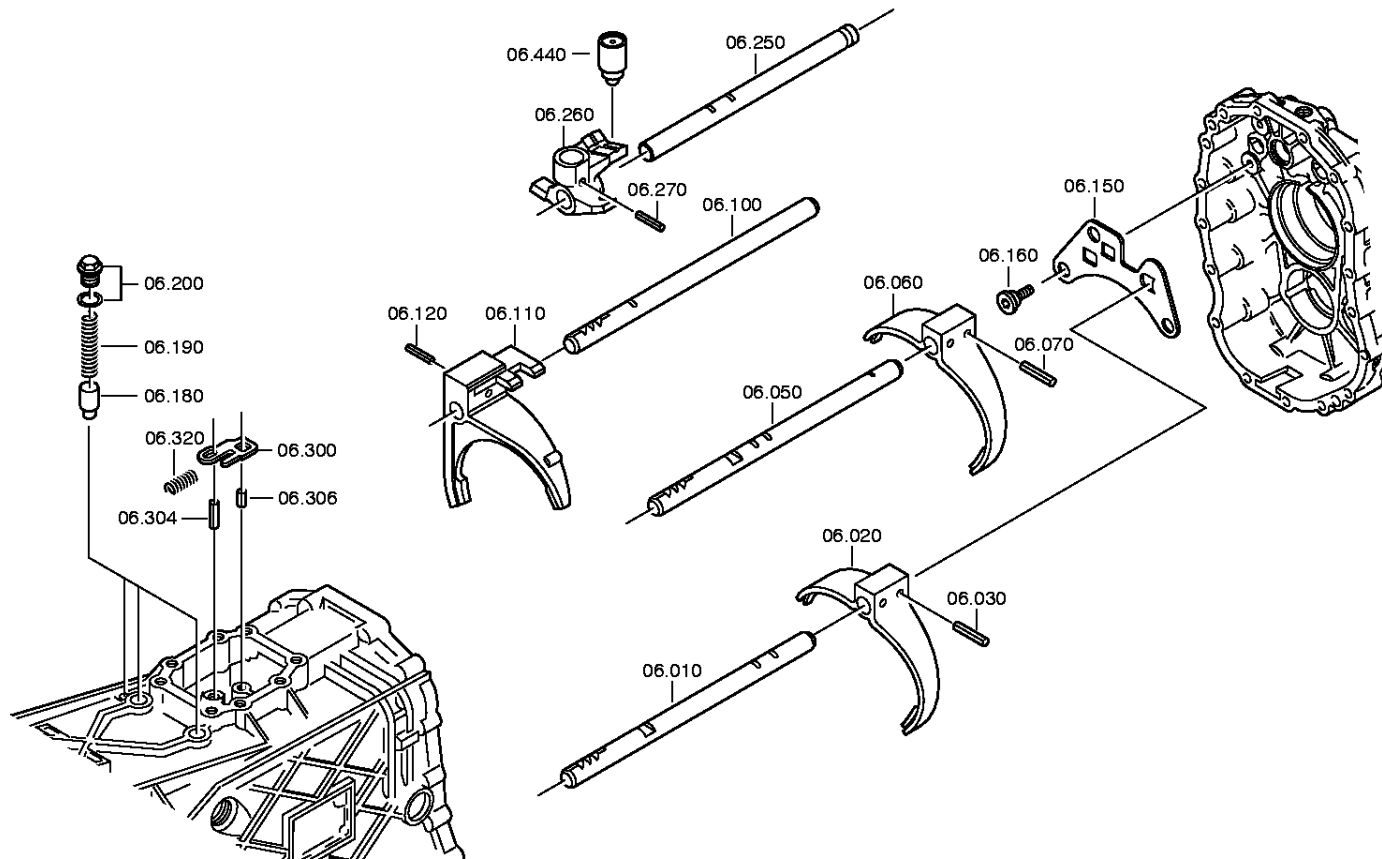

Plant

Page 2 from 2

Material number: 1307.050.410
Plant: 067.06.40-1
GEAR SHIFT SYSTEM

S 5-42 / COMESA COMPONENTES MECANICOS S.A
GEAR SHIFT SYSTEM

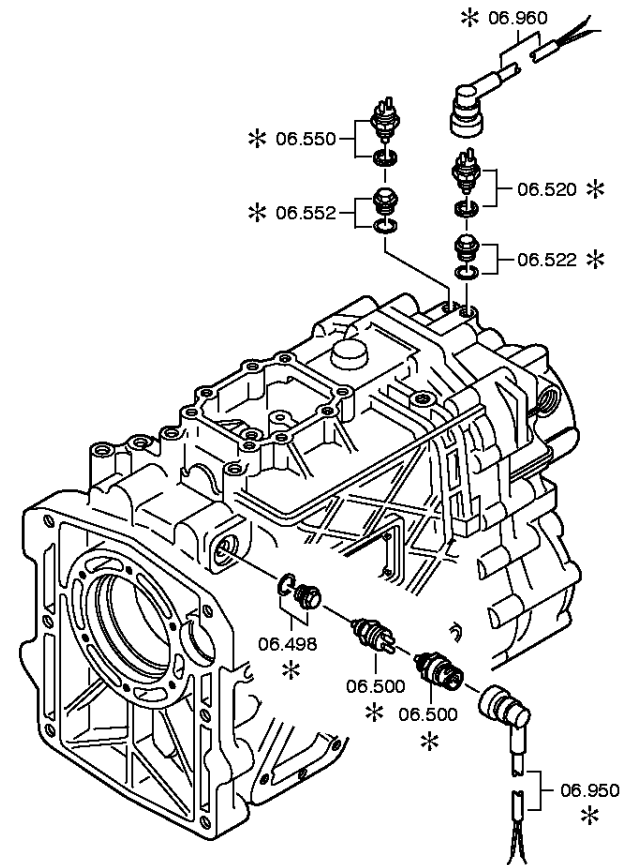

Parts list

Page 1 from 2

Material number: 1307.050.410

S 5-42 / COMESA COMPONENTES MECANICOS S.A

Plant: 067.06.05-1

Material-assembly-group-no: 1307.106.046



Pos.	Material number	Customer material	Name	Quantity	ME	Amend. no.	Techn. Info.	Weight	Rep kit	Alternative material
10	1307.306.219		GEAR SHIFT RAIL	1			5+RG IN 1307 306 221(1)	0,000		
20	1307.306.019		GEAR SHIFT FORK	1			ENTHALT.IN 1307 306 012(0)	0,000		
30	0631.329.069		SLOTPIN	2			6X30	4		
50	1307.306.245		GEAR SHIFT RAIL	1			1+2G IN 1307 306 244(1)	0,000		
60	1317.306.008		GEAR SHIFT FORK	1			1+2G	0,000		
70	0631.329.069		SLOTPIN	2			6X30	4		
100	1307.306.169		GEAR SHIFT RAIL	1			3+4G	0,000		
110	1307.206.027		GEAR SHIFT FORK	1		C01005551B10	KPL.3/4G* VERSTAERKT	0,000		
120	0631.329.069		SLOTPIN	1			6X30	4		
150	1307.306.230		SHIFTING INTERLOCK	1				0,000		
160	---		COLLAR SCREW	3			M6	0,000		
---	1307.306.121		COLLAR SCREW	3			M6	0,000		
180	1307.306.170		DETENT PIN	3				0,000		
190	0732.041.946		COMPRSPRING	3				0,000		
200	---		SCREW PLUG	3		Z00010172312	25N.M*DICHTRING M12X1,5	0,000		
---	0636.100.299		SCREW PLUG	3		Z00010172316	M12X1,5	0,000		
---	0634.801.027		SEALING RING	3		Z00010172316	12X16	0,000		
250	1307.306.260		GEAR SHIFT SHAFT	1				0,000		
260	1307.306.262		PIVOT DETENT	1		C01007889710	ENTHALT.IN 1307 306 261(0)	0,000		
270	0631.329.069		SLOTPIN	1			6X30	4		
300	1307.306.229		STOP PLATE	1				0,000		
304	0631.330.131		SLOTPIN	1			8X22	0,000		
306	0631.330.006		SLOTPIN	1			5X16	0,000		
320	0732.041.947		COMPRSPRING	1				0,000		
440	0501.206.456		GSHIFT DETENT	1			KPL. IN 0501 207 250(2)	0,000		

Parts list

Page 2 from 2

Material number: 1307.050.410

Plant: 067.06.05-1

Material-assembly-group-no: 1307.106.046

S 5-42 / COMESA COMPONENTES MECANICOS S.A



Pos.	Material number	Customer material	Name	Quantity	ME	Amend. no.	Techn. Info.	Weight	Rep kit	Alternative material
500	---		SWITCH	1			SCHL*40N.M* O.DICHTRING* BAJONETT	0,000		
---	0501.210.785		SWITCH	1			KPL.SCHL	0,000		
520	---		SWITCH	1			OEFF*40N.M*O. DICHTRING*ET16* BAJONETT	0,000		
---	0501.216.476		SWITCH	1			KPL.	0,000		

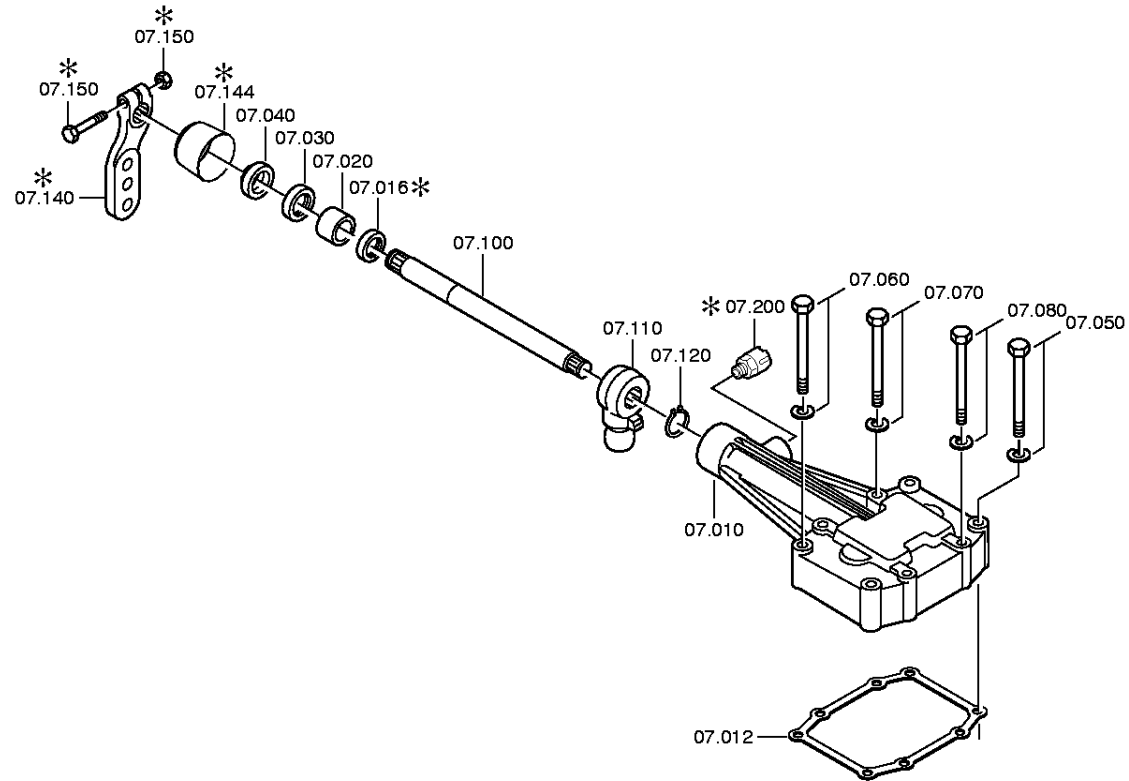

Parts list

Page 1 from 1

Material number: 1307.050.410

Plant: 067.07.02-1

Material-assembly-group-no: 1307.107.018

S 5-42 / COMESA COMPONENTES MECANICOS S.A



Pos.	Material number	Customer material	Name	Quantity	ME	Amend. no.	Techn. Info.	Weight	Rep kit	Alternative material
10	1307.306.247		GEAR SHIFT HOUSING	1			RE	0,000		
12	1307.306.034		GASKET	1			ENTHALT.IN 1308 307 010(2)	0,000		
16	0734.300.021		SHAFT SEAL	1			22X28X5*KACO	0,000		
20	0730.260.257		BEARING BUSH	1			ENTHALT.IN 0730 260 546(2)	0,000		
30	0634.302.143		SHAFT SEAL	1			22X35X7	0,000		
40	0734.307.260		SCRAPER	1			22X35X8/5 FA.CFW	0,000		
50	---		HEXAGON BOLT	2		Z00007058712	M8X50	0,000		
---	0636.016.404		HEXAGON BOLT	2		Z00007058717	M8X50	0,000		
---	0630.100.295		WASHER	2		Z00007158414		0,000		
60	---		HEXAGON BOLT	2		Z00007058712	M8X50	0,000		
---	0636.016.404		HEXAGON BOLT	2		Z00007058717	M8X50	0,000		
---	0630.100.295		WASHER	2		Z00007158414		0,000		
70	---		HEXAGON BOLT	2		Z00007058712	M8X50	0,000		
---	0636.016.404		HEXAGON BOLT	2		Z00007058717	M8X50	0,000		
---	0630.100.295		WASHER	2		Z00007158414		0,000		
80	---		HEXAGON BOLT	2		Z00007058712	M8X50	0,000		
---	0636.016.404		HEXAGON BOLT	2		Z00007058717	M8X50	0,000		
---	0630.100.295		WASHER	2		Z00007158414		0,000		
100	1306.306.042		GEAR SHIFT SHAFT	1			ENTHALT.IN 1317 307 001(2)	0,000		
110	1307.306.259		GSHIFT FINGER	1				0,000		
120	0630.531.005		RETAINING RING	1			16X1,5	0,000		
144	1324.307.268		PROTECTING CAP	1		Z00009174312		0,000		
200	---		BREATHER	1			M10X1KEG	0,000		
---	0501.202.797		BREATHER	1			KPL.	30		
---	0501.218.540		BREATHER	1				0,000		

Plant

Page 1 from 2

Material number: 1307.050.410
Plant: 067.93.31-1
CLUTCH RELEASE DEVICE

S 5-42 / COMESA COMPONENTES MECANICOS S.A
CLUTCH RELEASE DEVICE

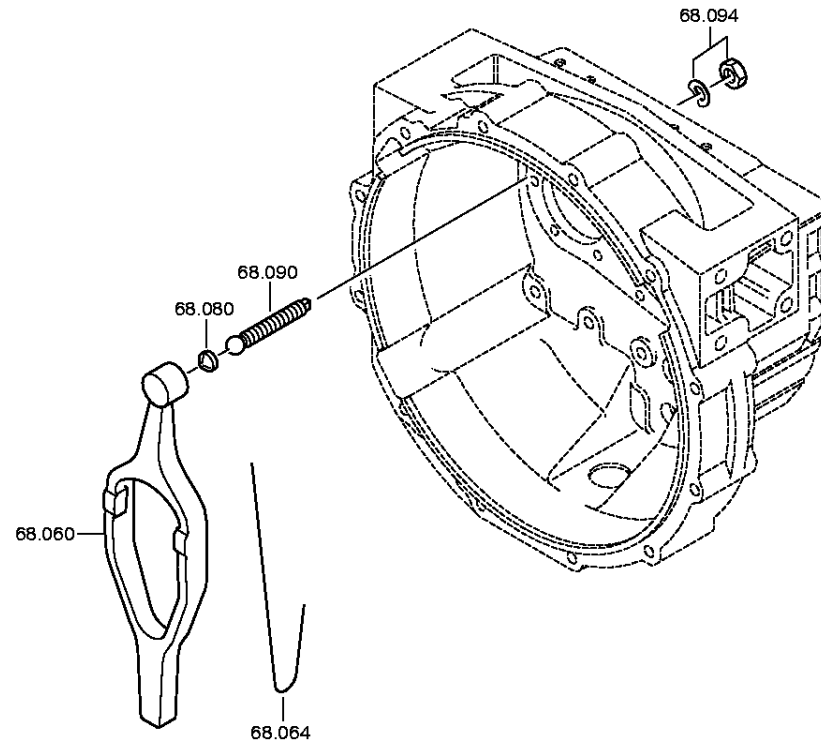

Plant

Page 2 from 2

Material number: 1307.050.410
Plant: 067.93.69-1
CLUTCH RELEASE DEVICE

S 5-42 / COMESA COMPONENTES MECANICOS S.A
CLUTCH RELEASE DEVICE

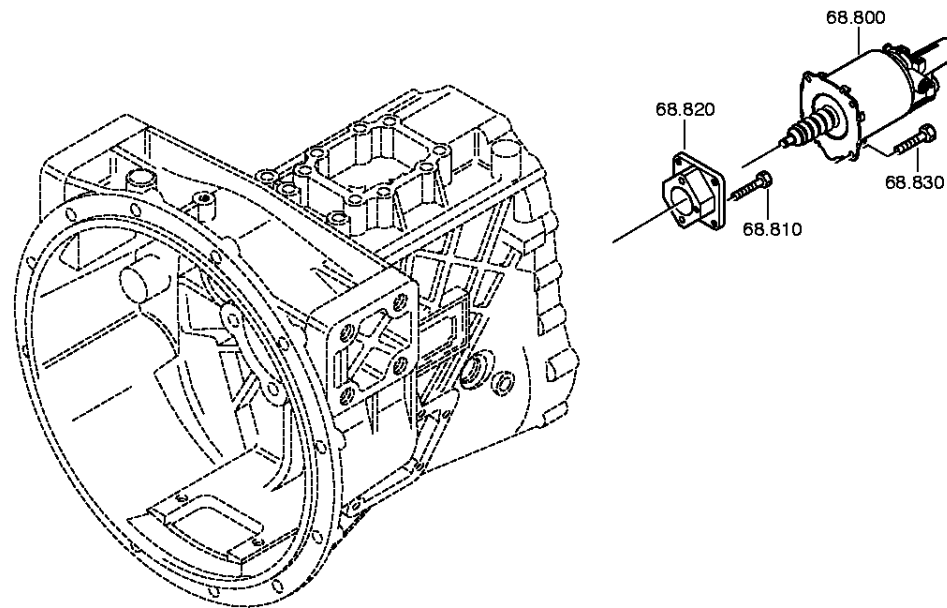

Parts list

Page 1 from 1

Material number: 1307.050.410

S 5-42 / COMESA COMPONENTES MECANICOS S.A

Plant: 067.93.31-1

Material-assembly-group-no: 1307.168.012



Pos.	Material number	Customer material	Name	Quantity	ME	Amend. no.	Techn. Info.	Weight	Rep kit	Alternative material
60	6060.268.004		RELEASE FORK	1			KPL.	0,000		
80	0501.307.306		BALL CUP	1				0,000		
90	6060.368.066		BALL PIN	1		Z00009173210		0,000		
94	---		HEXAGON NUT	1			M16	0,000		
---	0637.100.245		HEXAGON NUT	1		Z00007283310	M16	0,000		
---	0630.100.245		SPRING WASHER	1		Z00007159613		0,000		
800	0501.007.540		CLUTCH CYLINDER	1				0,000		
810	0636.016.414		HEXAGON BOLT	3		Z00007059111	M8X28	0,000		
820	1307.301.234		ADAPTER PLATE	1				0,000		
830	0636.100.622		HEXAGON BOLT	4		Z00009042710	M8X16	0,000		